

370 DGC (Diaphragm Gauge) STANDARD DIMENSIONS

HIRLEKAR PRECISION

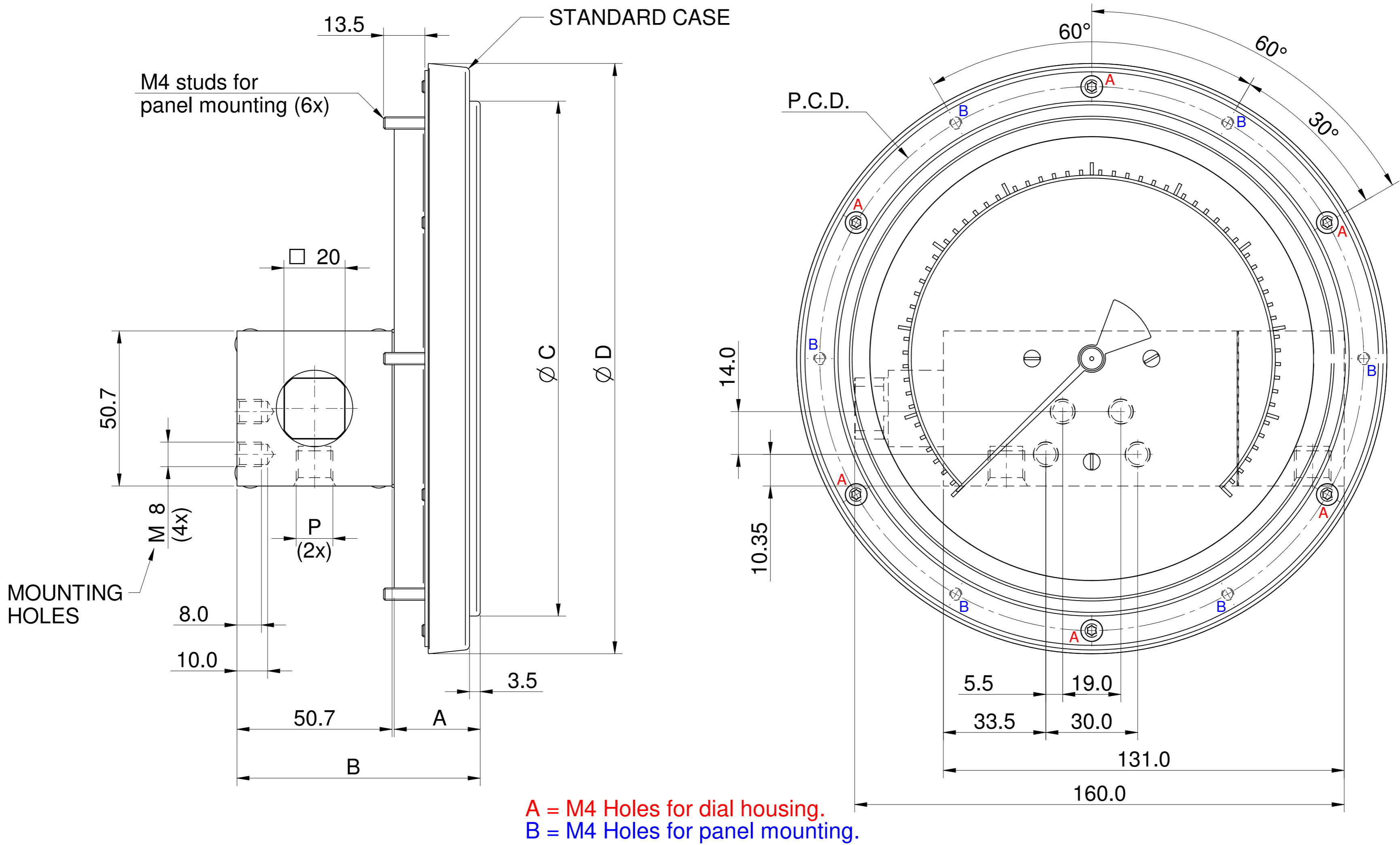

DIAL SIZE	P	A	B	Ø C	Ø D	P.C.D.
115 (4.5")	1/4" BSP - 1/4" NPT	28.10	79.30	133.30	157.93	143.00
150 (6.0")	1/4" BSP - 1/4" NPT	28.10	79.50	168.30	192.93	177.80

Gauge+Reed switch with DIN Plug

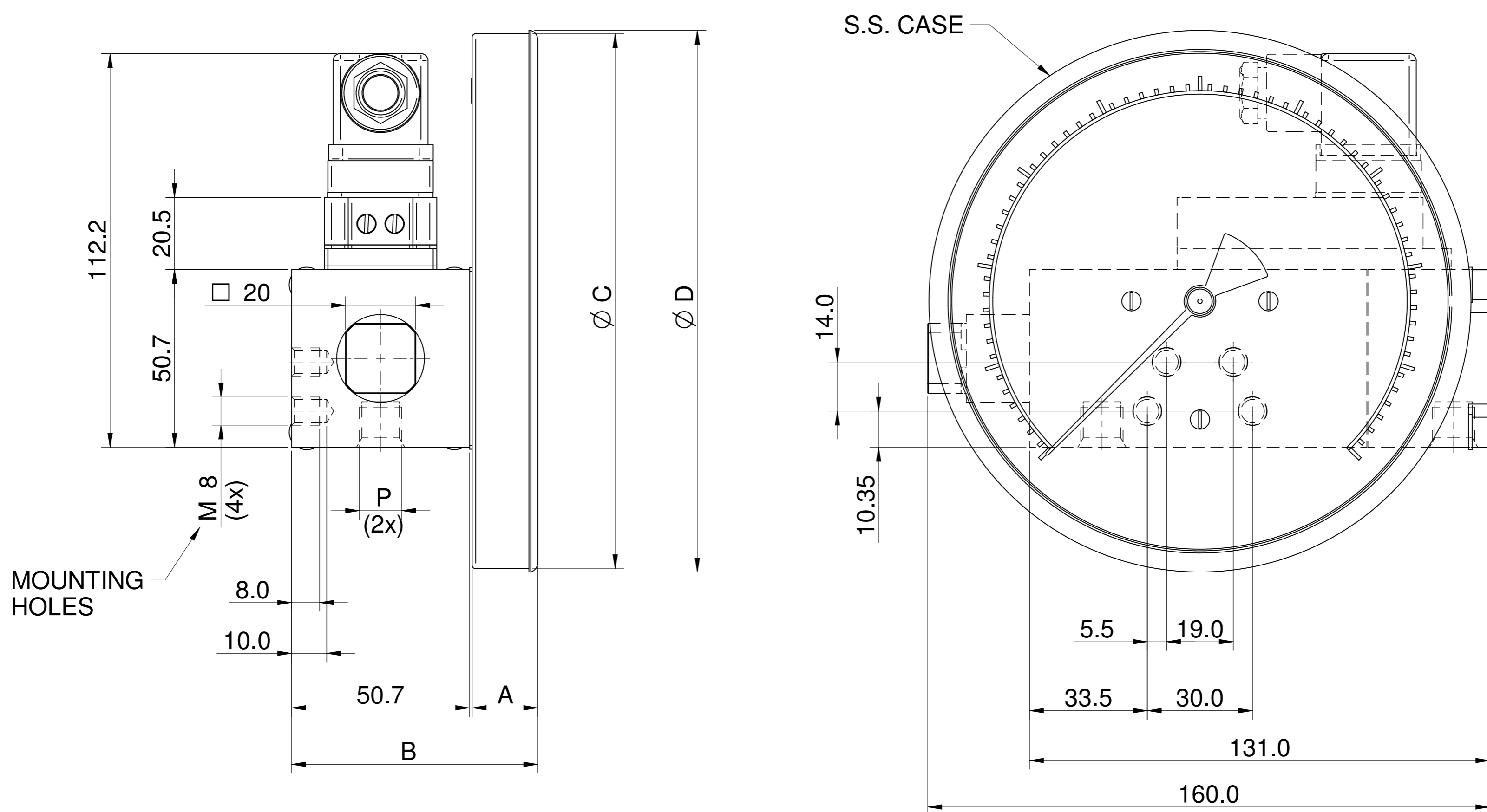

DIAL SIZE	P	A	B	Ø C	Ø D
80 (3.5")	1/4" BSP - 1/4" NPT	18.48	69.68	82.00	83.00
100 (4.0")	1/4" BSP - 1/4" NPT	18.50	69.70	102.00	104.30
115 (4.5")	1/4" BSP - 1/4" NPT	18.56	69.76	117.00	119.30
150 (6.0")	1/4" BSP - 1/4" NPT	18.71	70.11	152.40	154.30

STANDARD DIMENSIONS

Gauge + Reed switch with Terminal Strip

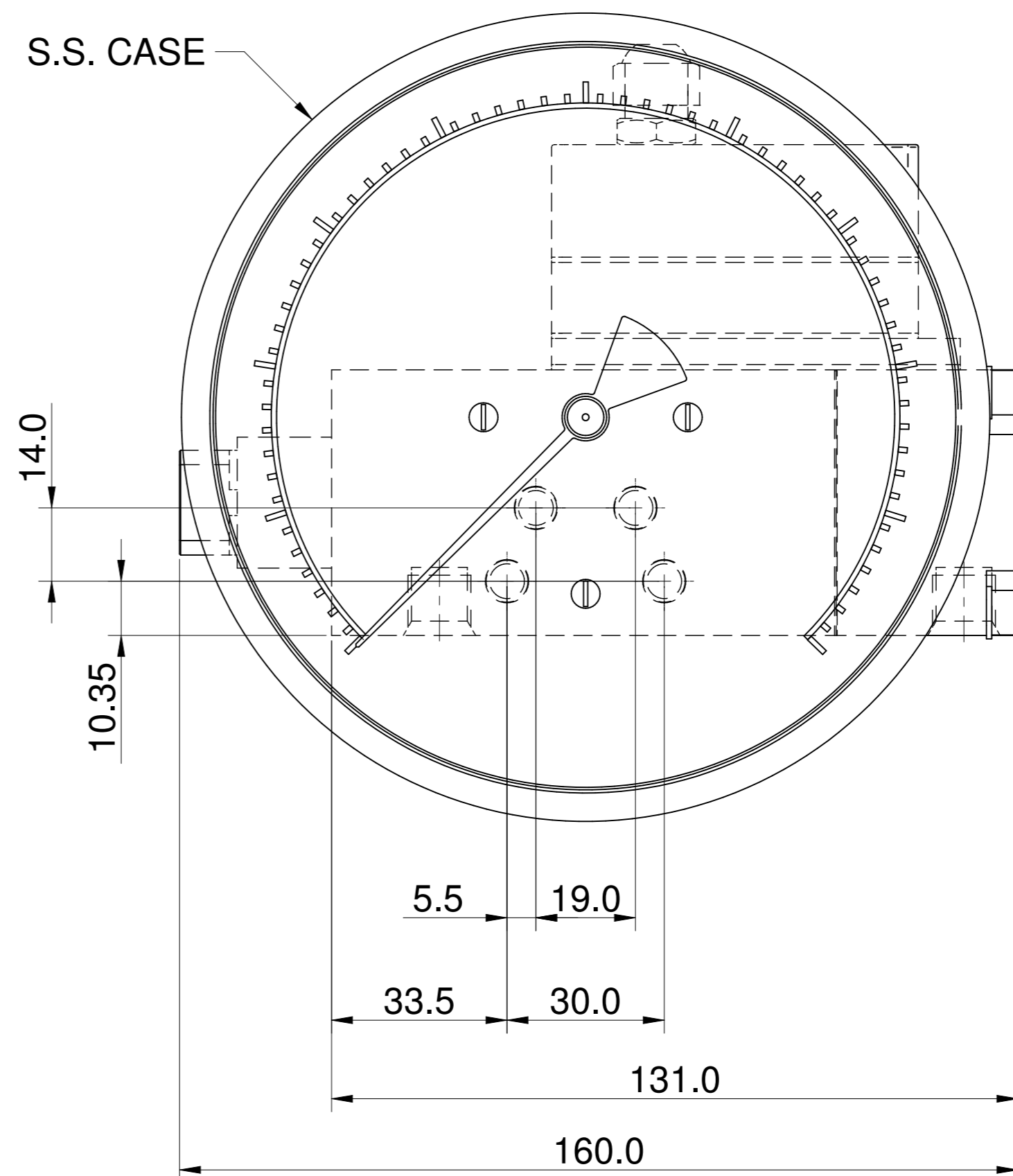
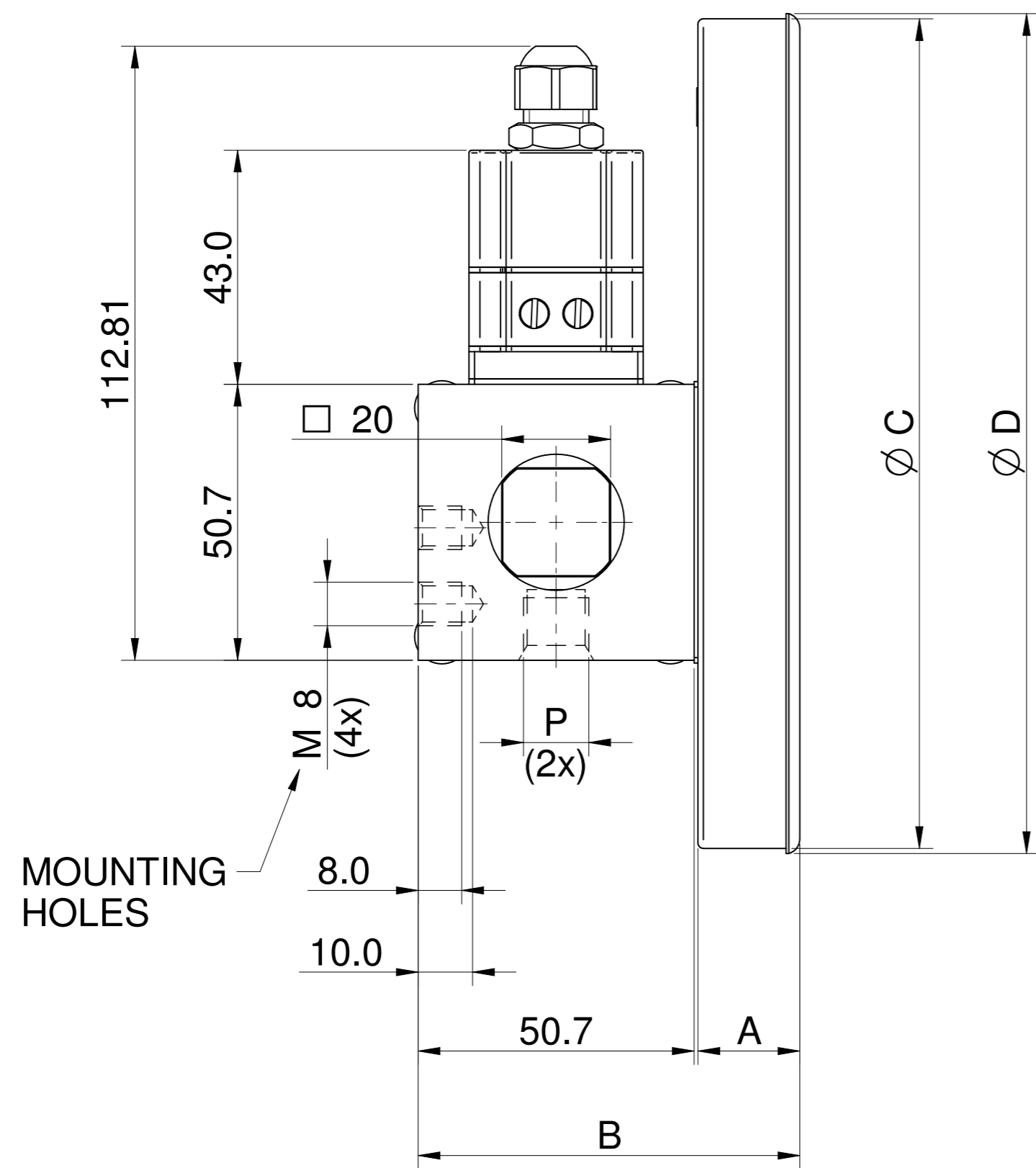

DIAL SIZE	P	A	B	Ø C	Ø D
80 (3.5")	1/4" BSP - 1/4" NPT	18.48	69.68	82.00	83.00
100 (4.0")	1/4" BSP - 1/4" NPT	18.50	69.70	102.00	104.30
115 (4.5")	1/4" BSP - 1/4" NPT	18.56	69.76	117.00	119.30
150 (6.0")	1/4" BSP - 1/4" NPT	18.71	70.11	152.40	154.30

Gauge + Reed switch with Terminal Strip & 1/2" Conduit Connection

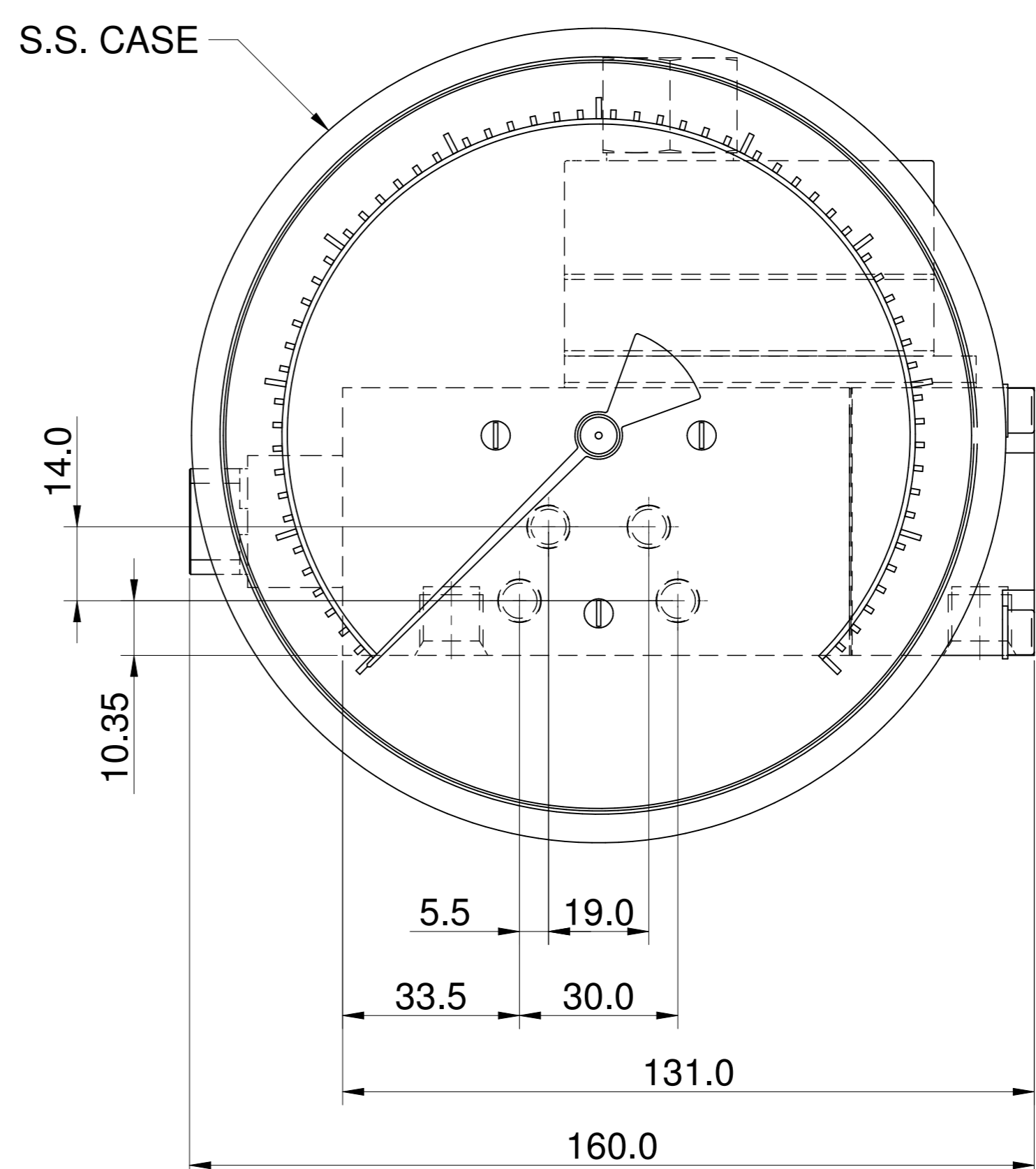
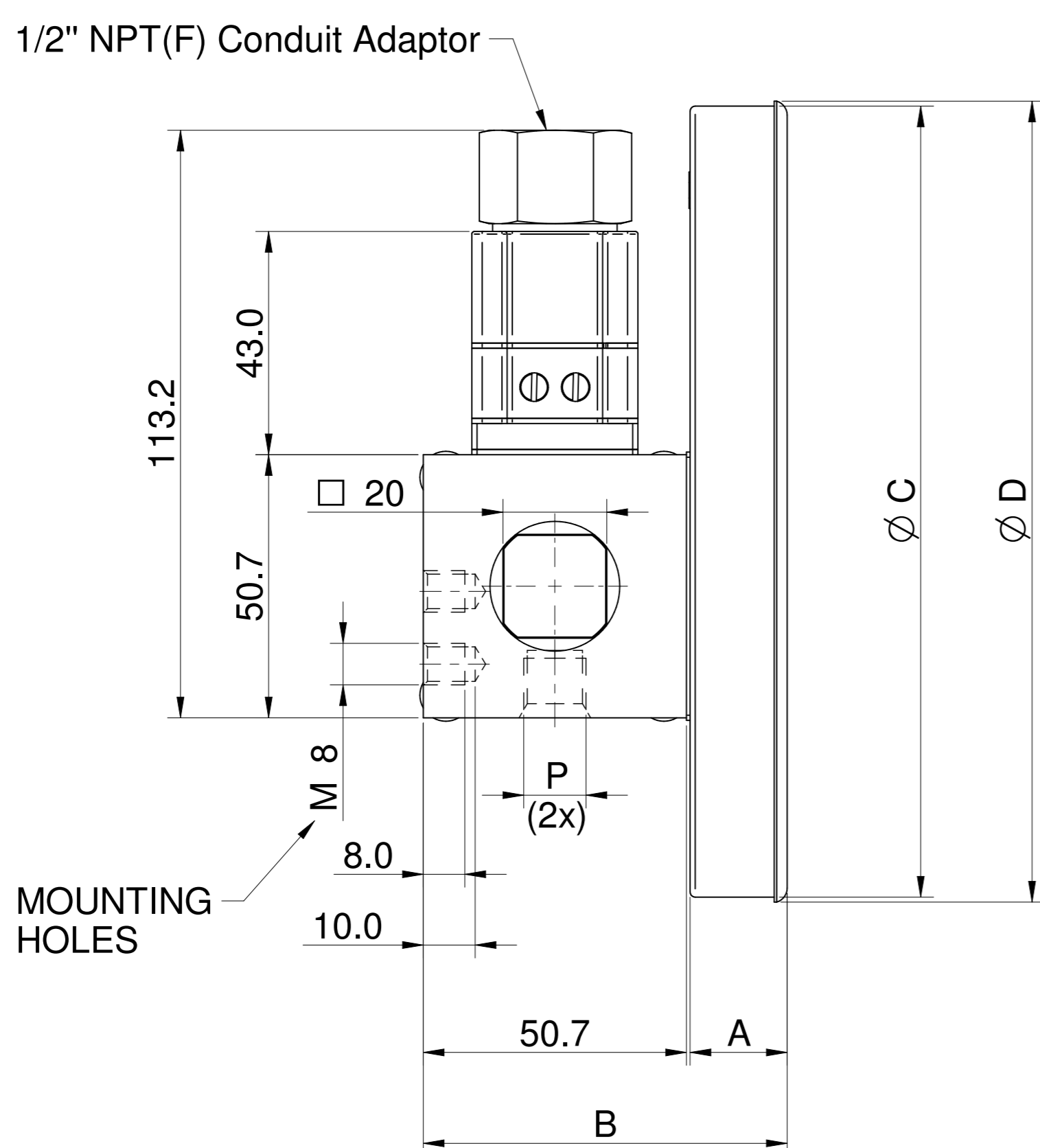

370 DGC Level Gauge with Combo

Gauge + Manifold + 1/2" Pressure gauge Connection

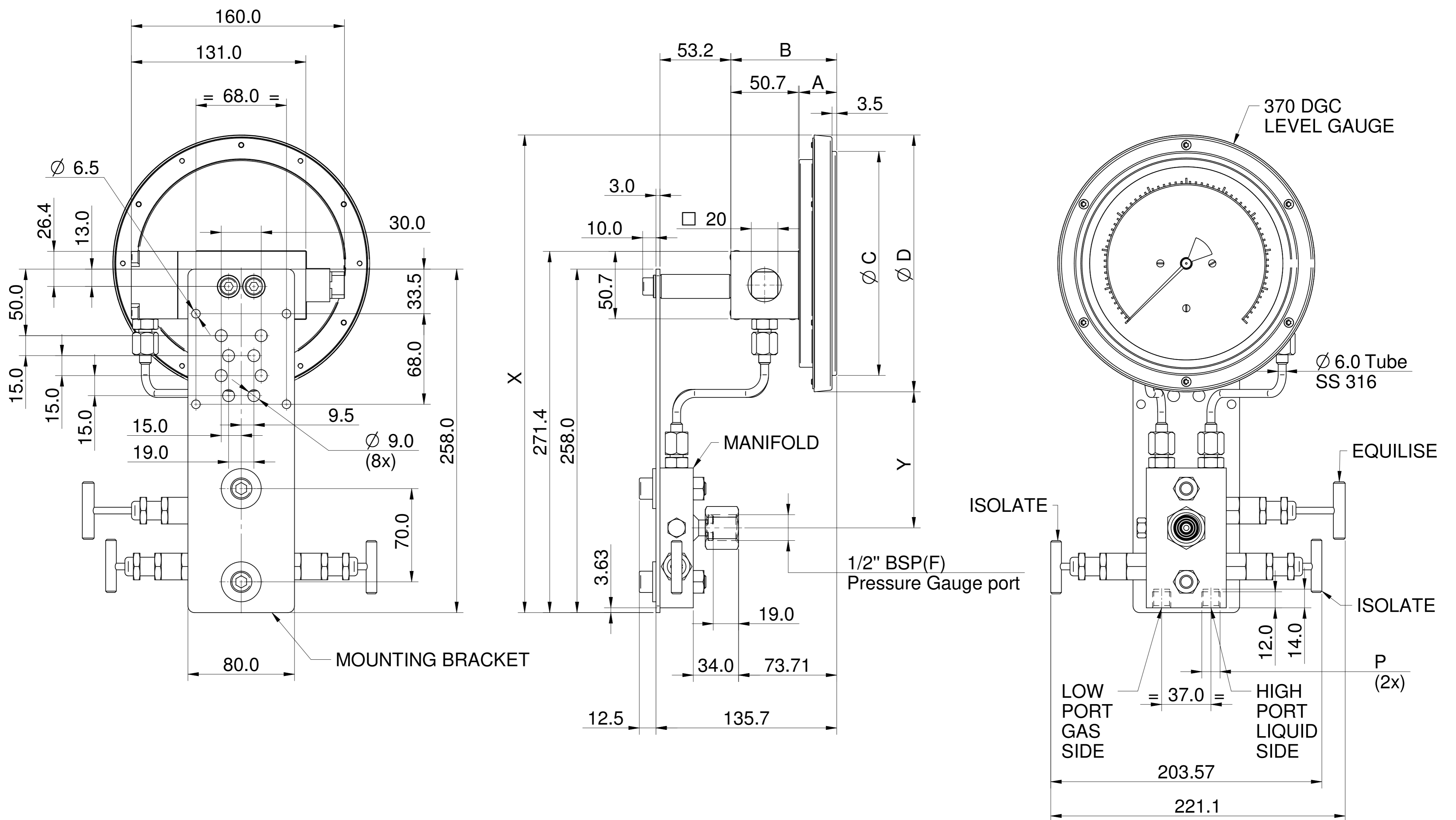

EP CASE :

DIAL SIZE	P	A	B	Ø C	Ø D	X	Y
115 (4.5")	1/4" BSP	28.10	79.30	133.30	157.93	341.27	119.70
150 (6.0")	1/4" BSP	28.10	79.50	168.30	192.93	358.77	102.20

S.S. CASE

DIAL SIZE	P	A	B	Ø C	Ø D	X	Y
80 (3.5")	1/4" BSP	18.48	69.68	82.00	83.00	303.80	157.17
100 (4.0")	1/4" BSP	18.50	69.70	102.00	104.30	314.45	146.52
115 (4.5")	1/4" BSP	18.56	69.76	117.00	119.30	321.95	139.02
150 (6.0")	1/4" BSP	18.71	70.11	152.40	154.30	339.45	121.52

370 DGC Level Gauge with Combo

Gauge + Manifold + 1/2" Pressure gauge

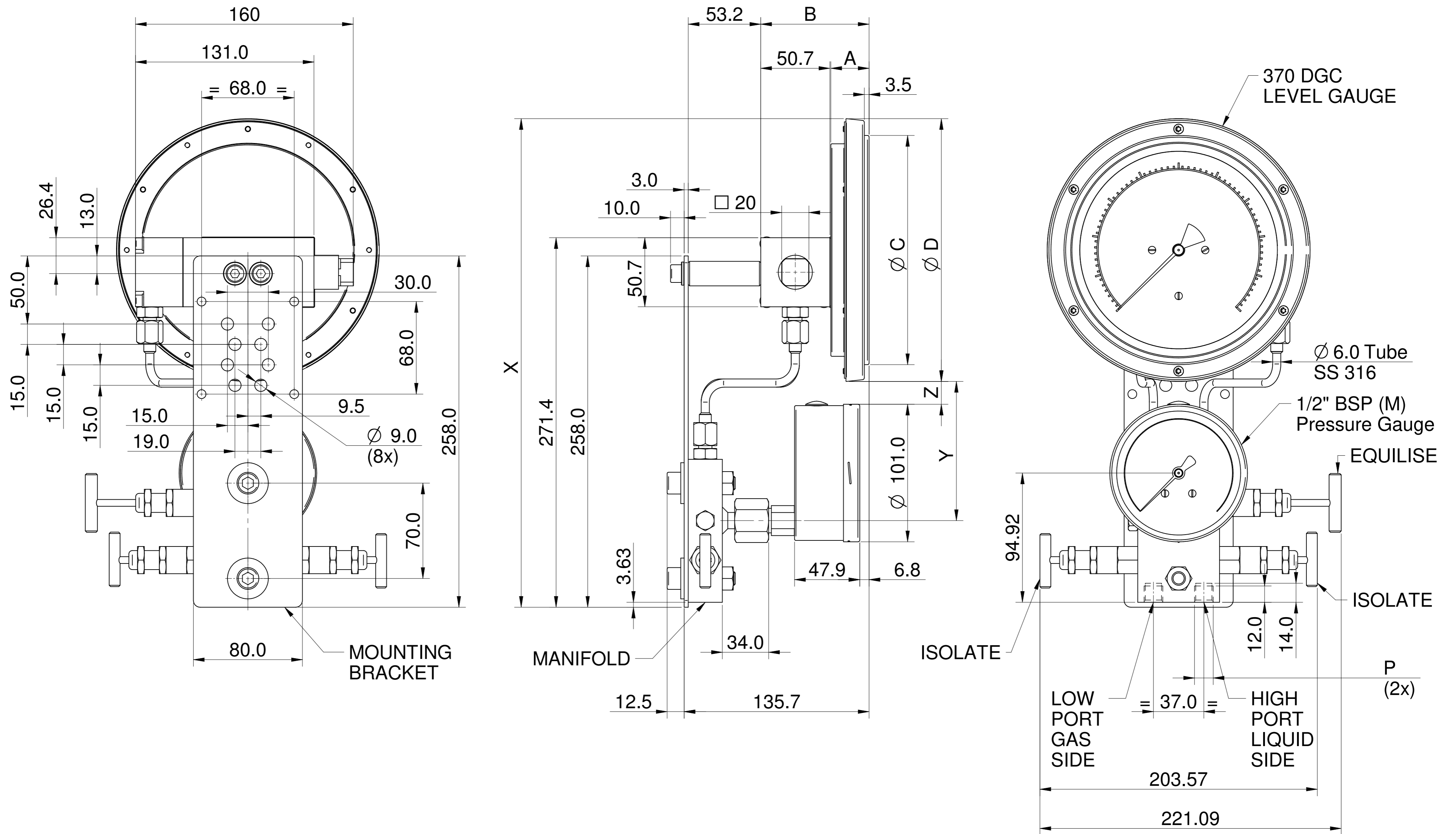

EP CASE :

DIAL SIZE	P	A	B	Ø C	Ø D	X	Y	Z
115 (4.5")	1/4" BSP	28.10	79.30	133.30	157.93	341.27	119.70	34.28
150 (6.0")	1/4" BSP	28.10	79.50	168.30	192.93	358.77	102.20	16.78

S.S. CASE

DIAL SIZE	P	A	B	Ø C	Ø D	X	Y	Z
80 (3.5")	1/4" BSP	18.48	69.68	82.00	83.00	303.80	157.17	71.75
100 (4.0")	1/4" BSP	18.50	69.70	102.00	104.30	314.45	146.52	61.10
115 (4.5")	1/4" BSP	18.56	69.76	117.00	119.30	321.95	139.02	53.60
150 (6.0")	1/4" BSP	18.71	70.11	152.40	154.30	339.45	121.52	36.10

370 DGC Level Gauge with Combo

Gauge + switch with DIN Plug + Manifold + 1/2" Pressure gauge

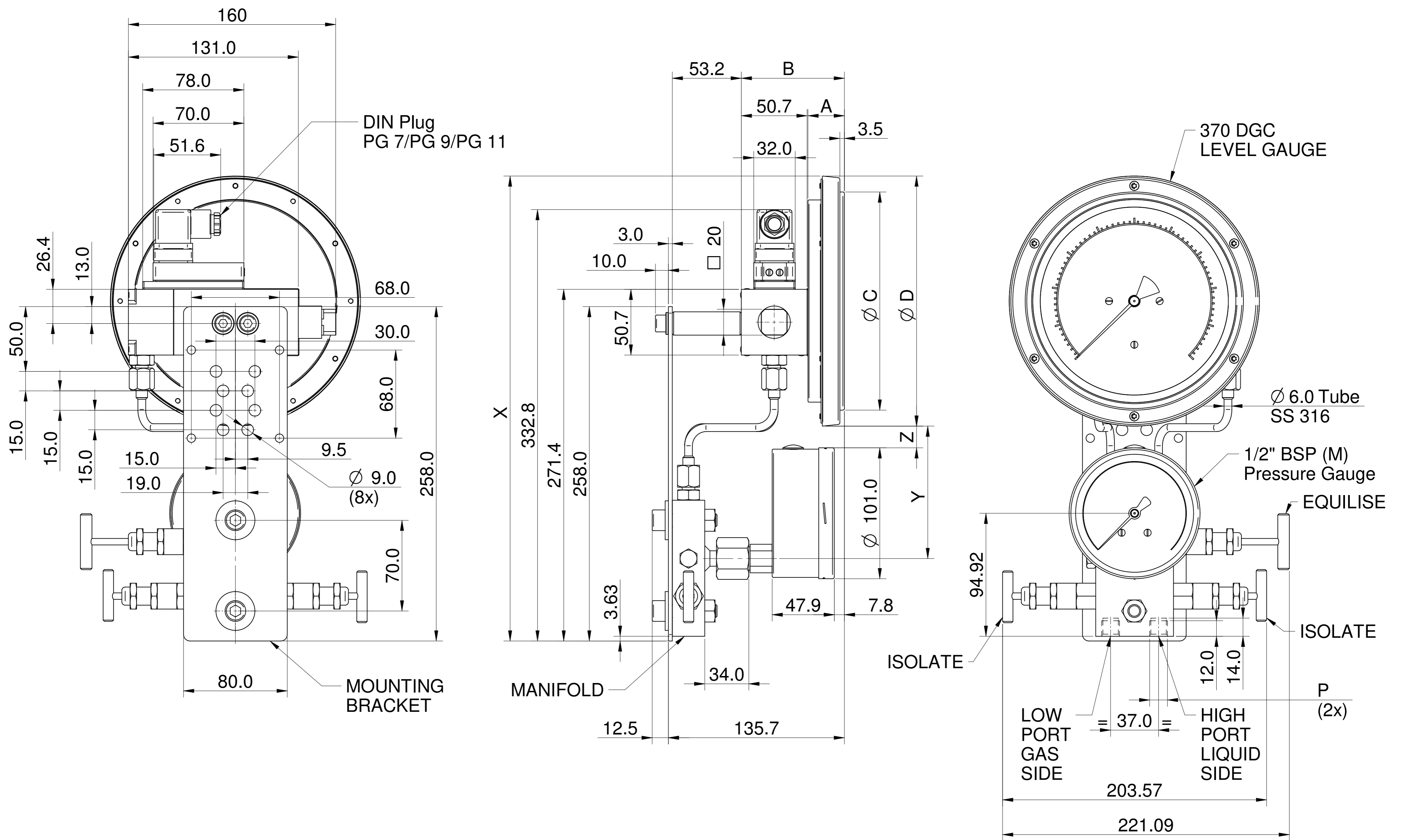

EP CASE :

DIAL SIZE	P	A	B	Ø C	Ø D	X	Y	Z
115 (4.5")	1/4" BSP	28.10	79.30	133.30	157.93	341.27	119.70	34.28
150 (6.0")	1/4" BSP	28.10	79.50	168.30	192.93	358.77	102.20	16.78

S.S. CASE

DIAL SIZE	P	A	B	Ø C	Ø D	X	Y	Z
80 (3.5")	1/4" BSP	18.48	69.68	82.00	83.00	303.80	157.17	71.75
100 (4.0")	1/4" BSP	18.50	69.70	102.00	104.30	314.45	146.52	61.10
115 (4.5")	1/4" BSP	18.56	69.76	117.00	119.30	321.95	139.02	53.60
150 (6.0")	1/4" BSP	18.71	70.11	152.40	154.30	339.45	121.52	36.10