

400 DGC

(Diaphragm Gauge)

STANDARD DIMENSIONS

HIRLEKAR
PRECISION

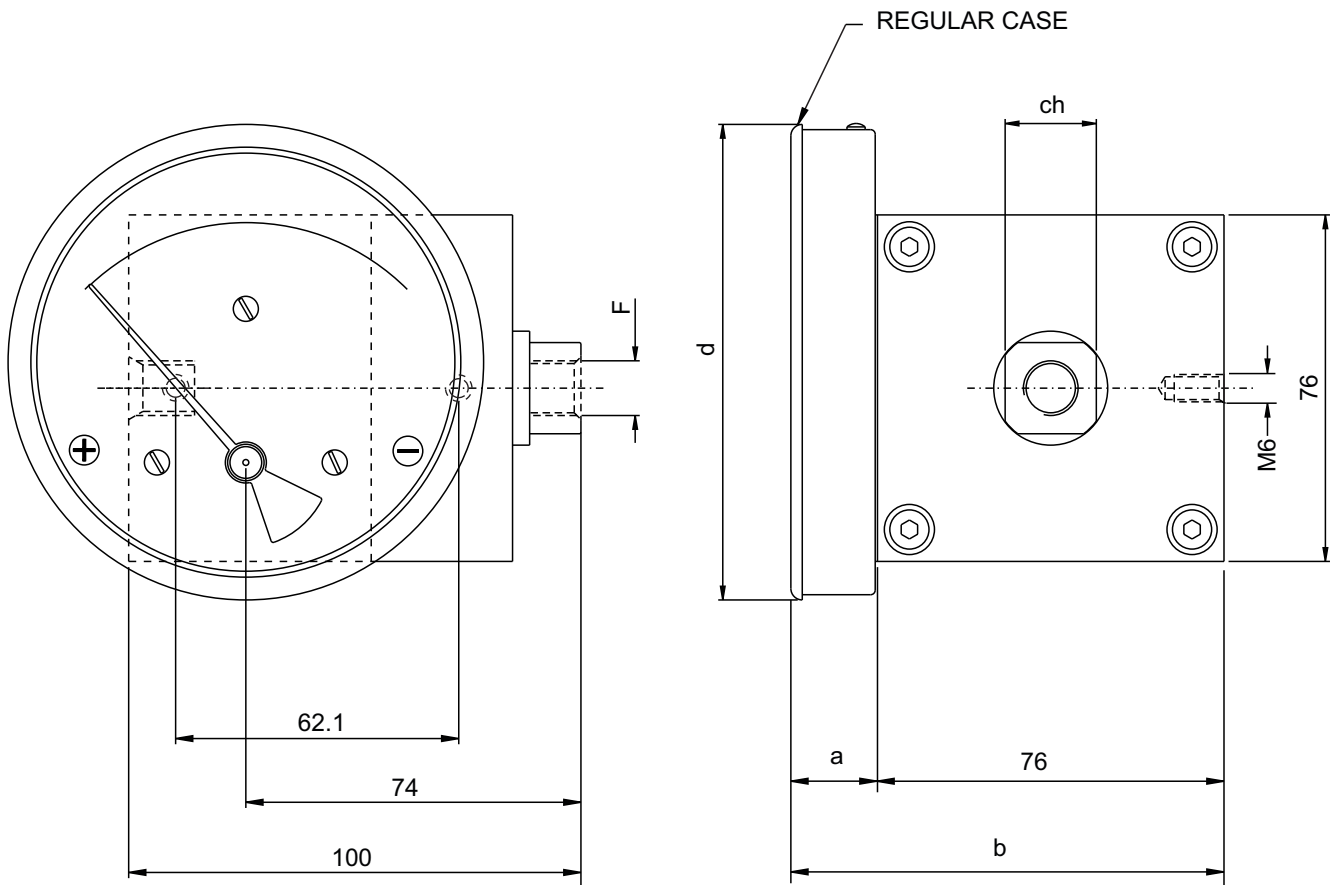

DIAL Ø	F	a	b	d	ch
80 (3.5")	1/4"BSP - 1/4"NPT	19	95	83	20
100 (4")	1/4"BSP - 1/4"NPT	19	95	104.3	20
115 (4.5")	1/4"BSP - 1/4"NPT	19	95	119.7	20
150 (6")	1/4"BSP - 1/4"NPT	19	95	154.3	20

Gauge with flange

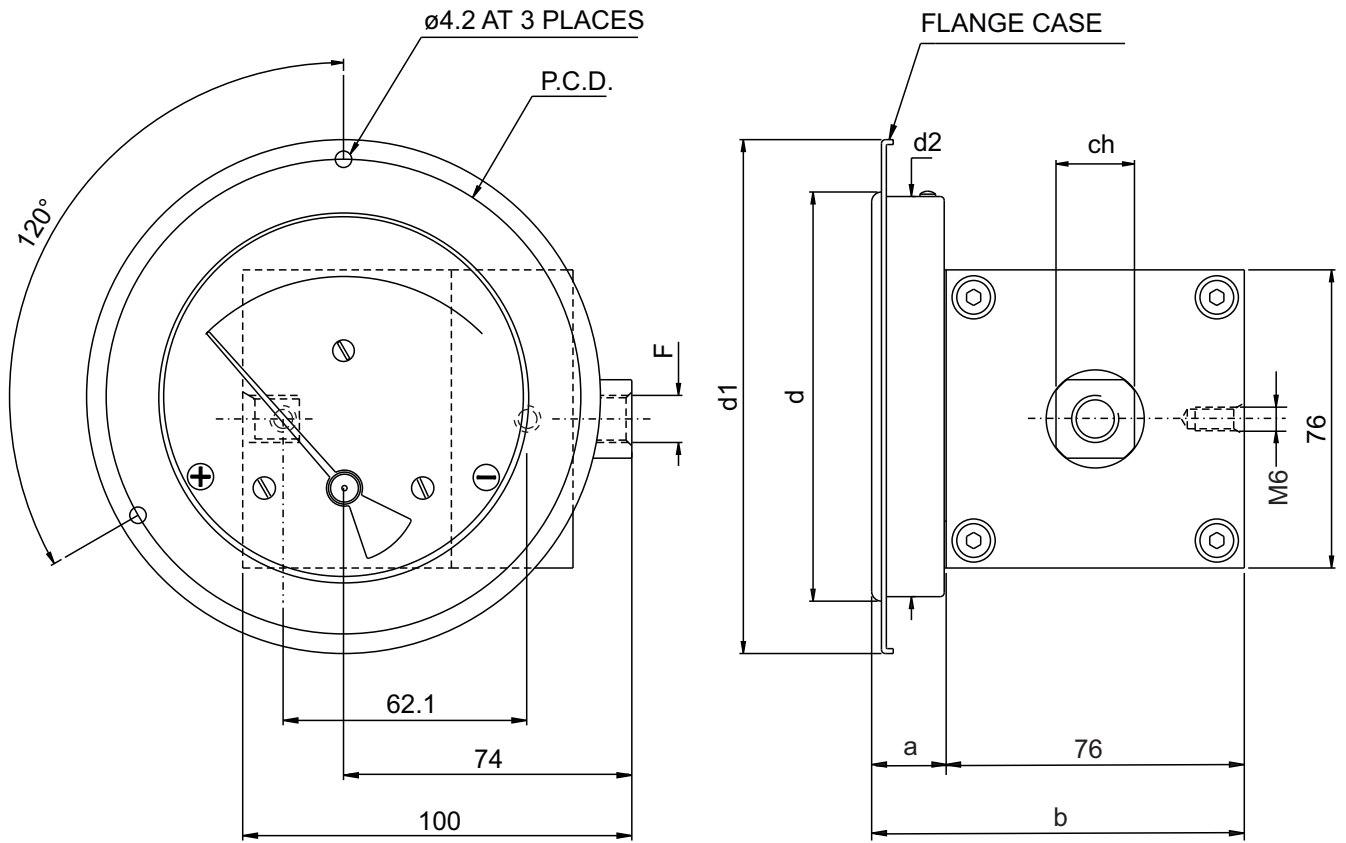

DIAL Ø	F	a	b	d1	d2	ch	p. c. d	d
80 (3.5")	1/4" BSP - 1/4" NPT	19	95	109	82.0	20	99	83.0
100 (4.0")	1/4" BSP - 1/4" NPT	19	95	131	102.0	20	121	104.3
115 (4.5")	1/4" BSP - 1/4" NPT	19	95	146	117.0	20	136	119.7
150 (6.0")	1/4" BSP - 1/4" NPT	19	95	181	152.5	20	171	154.3

* PANEL CUTOUT = d + 1 mm.

Gauge + Reedswitch with DIN Plug

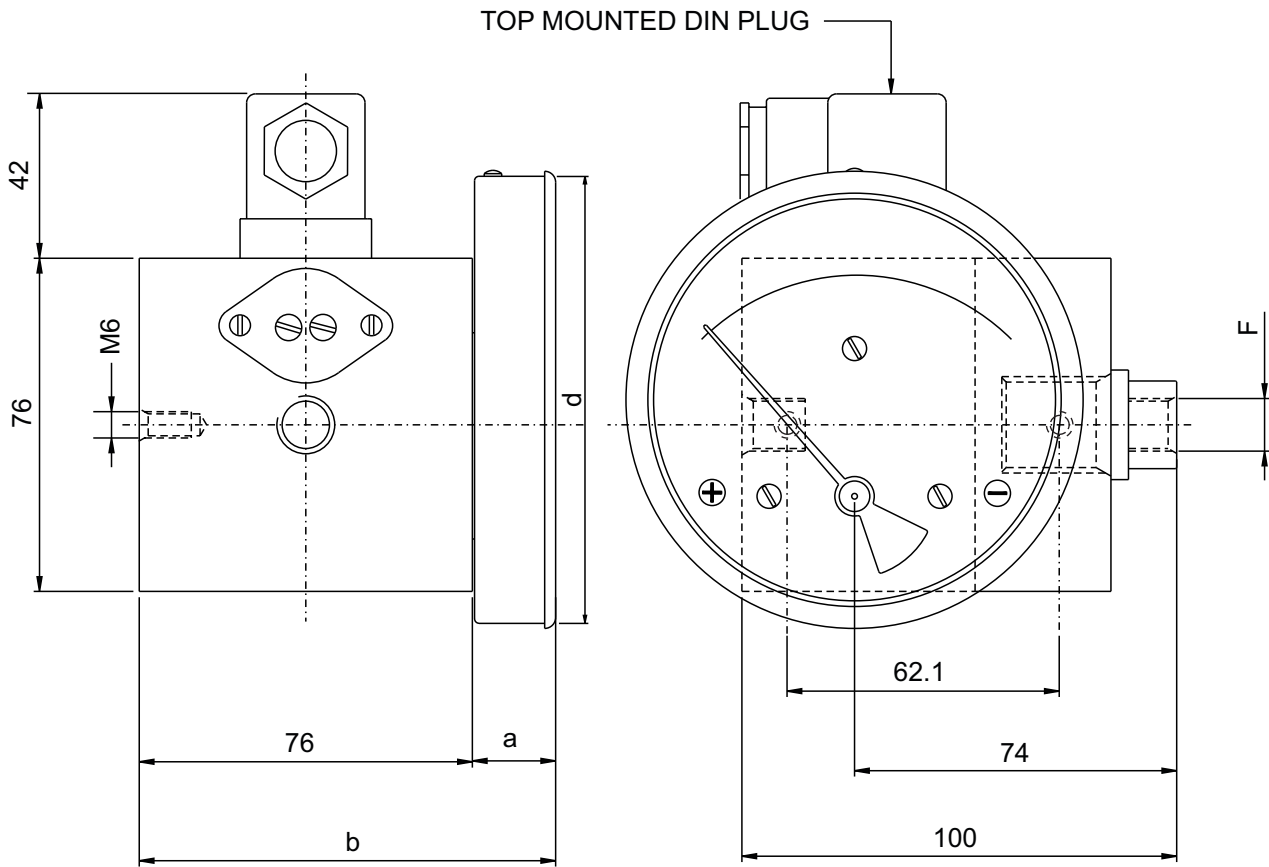

DIAL Ø	F	a	b	d
80 (3.5")	1/4"BSP - 1/4"NPT	19	95	83
100 (4")	1/4"BSP - 1/4"NPT	19	95	104.3
115 (4.5")	1/4"BSP - 1/4"NPT	19	95	119.7
150 (6")	1/4"BSP - 1/4"NPT	19	95	154.3