

# CZ 300DGC

(Diaphragm Gauge)

**HIRLEKAR**  
PRECISION

## STANDARD DIMENSIONS

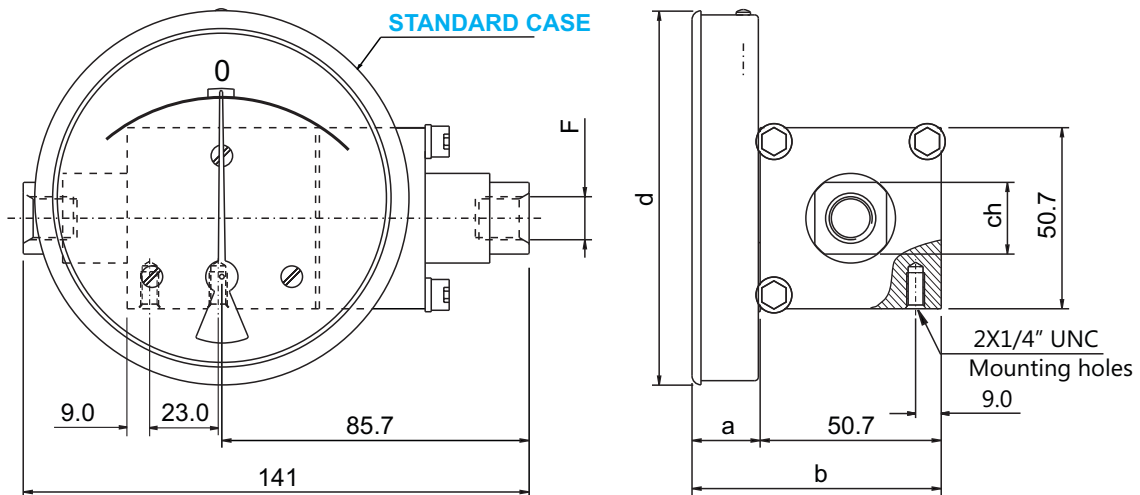

DIAL $\varnothing$	F	a	b	d	ch
63 (2.5")	1/4" BSP - 1/4" NPT	19	69.7	66	20
80 (3.5")	1/4" BSP - 1/4" NPT	19	69.7	83	20
100 (4")	1/4" BSP - 1/4" NPT	19	69.7	104.3	20
115 (4.5")	1/4" BSP - 1/4" NPT	19	69.7	119.7	20
150 (6")	1/4" BSP - 1/4" NPT	19	69.7	154.3	20

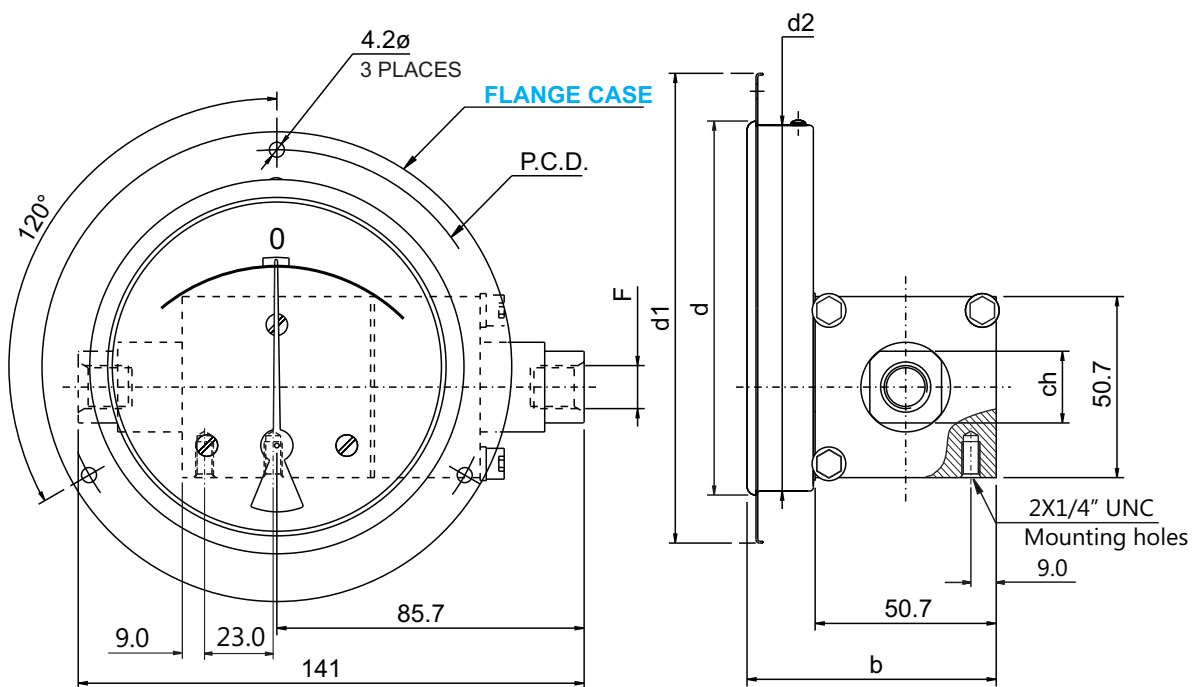

DIAL $\varnothing$	F	a	b	d1	d2	ch	p.c.d.	* d
63 (2.5")	1/4" BSP - 1/4" NPT	19	69.7	93	65	20	83	66
80 (3.5")	1/4" BSP - 1/4" NPT	19	69.7	109	82	20	99	83
100 (4")	1/4" BSP - 1/4" NPT	19	69.7	131	102	20	121	104.3
115 (4.5")	1/4" BSP - 1/4" NPT	19	69.7	146	117	20	136	119.7
150 (6")	1/4" BSP - 1/4" NPT	19	69.7	181	152.5	20	171	154.3

\* PANEL CUTOUT = d + 1

## Gauge + Switch with Reed contact

### with DIN plug

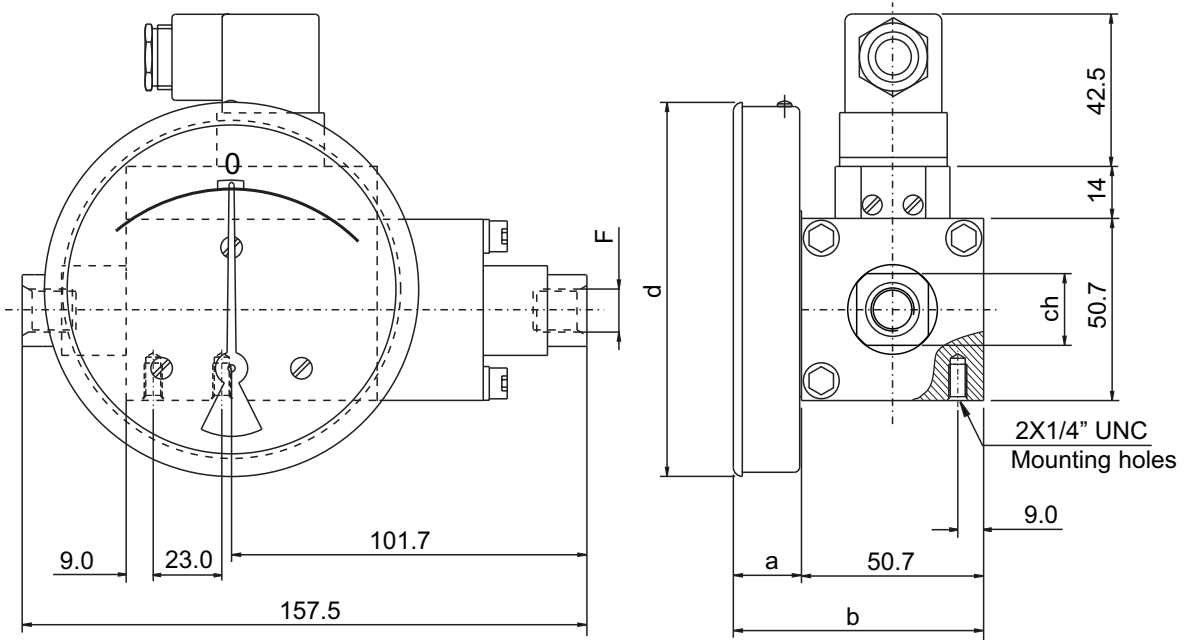

DIAL $\varnothing$	F	a	b	d	ch
63 (2.5")	1/4" BSP - 1/4" NPT	19	69.7	66	20
80 (3.5")	1/4" BSP - 1/4" NPT	19	69.7	83	20
100 (4")	1/4" BSP - 1/4" NPT	19	69.7	104.3	20
115 (4.5")	1/4" BSP - 1/4" NPT	19	69.7	119.7	20
150 (6")	1/4" BSP - 1/4" NPT	19	69.7	154.3	20

### with Terminal strip

