

CZ 400DGC

(Diaphragm Gauge)

HIRLEKAR PRECISION

STANDARD DIMENSIONS

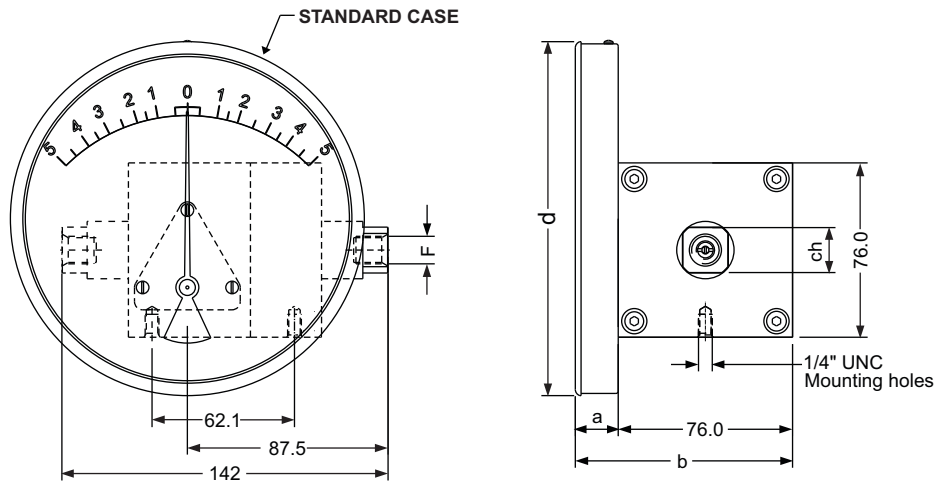

DIAL \varnothing	F	a	b	d	ch
80 (3.5")	1/4" BSP - 1/4" NPT	19	95	83	20
100 (4")	1/4" BSP - 1/4" NPT	19	95	104.3	20
115 (4.5")	1/4" BSP - 1/4" NPT	19	95	119.7	20
150 (6")	1/4" BSP - 1/4" NPT	19	95	154.3	20

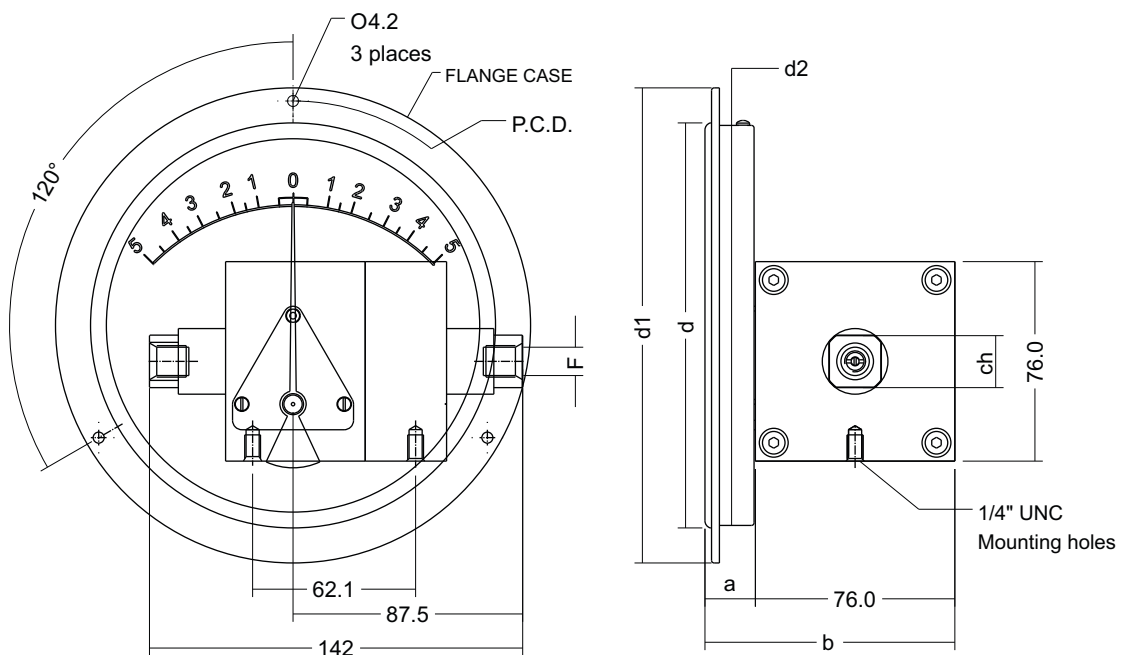

DIAL \varnothing	F	a	b	d1	d2	ch	p.c.d.	* d
80 (3.5")	1/4" BSP - 1/4" NPT	19	95	109	82	20	99	83
100 (4")	1/4" BSP - 1/4" NPT	19	95	131	102	20	121	104.3
115 (4.5")	1/4" BSP - 1/4" NPT	19	95	146	117	20	136	119.7
150 (6")	1/4" BSP - 1/4" NPT	19	95	181	152.5	20	171	154.3

* PANEL CUTOUT = d + 1