

# 200 DPG (Piston Gauge)

## STANDARD DIMENSIONS

**HIRLEKAR  
PRECISION**

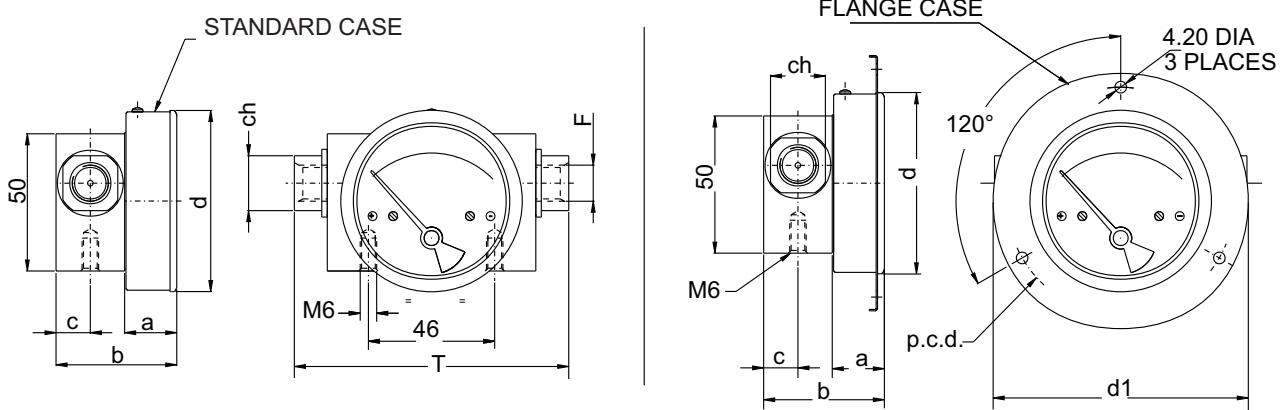

DIAL Ø	F	a	b	c	d	d1	T	ch	p.c.d.
50 (2")	1/4"BSP - 1/4"NPT	18	43	12.5	53	79	100	20	69
63 (2.5")	1/4"BSP - 1/4"NPT	19	44	12.5	66	93	100	20	83
80 (3.5")	1/4"BSP - 1/4"NPT	19	44	12.5	83	109	100	20	99
100 (4")	1/4"BSP - 1/4"NPT	19	44	12.5	104.3	131	100	20	121
115 (4.5")	1/4"BSP - 1/4"NPT	19	44	12.5	119.7	146	100	20	136
150 (6")	1/4"BSP - 1/4"NPT	19	44	12.5	154.3	181	100	20	171

\* PANEL CUT OUT = d + 1

## Mounting Bracket

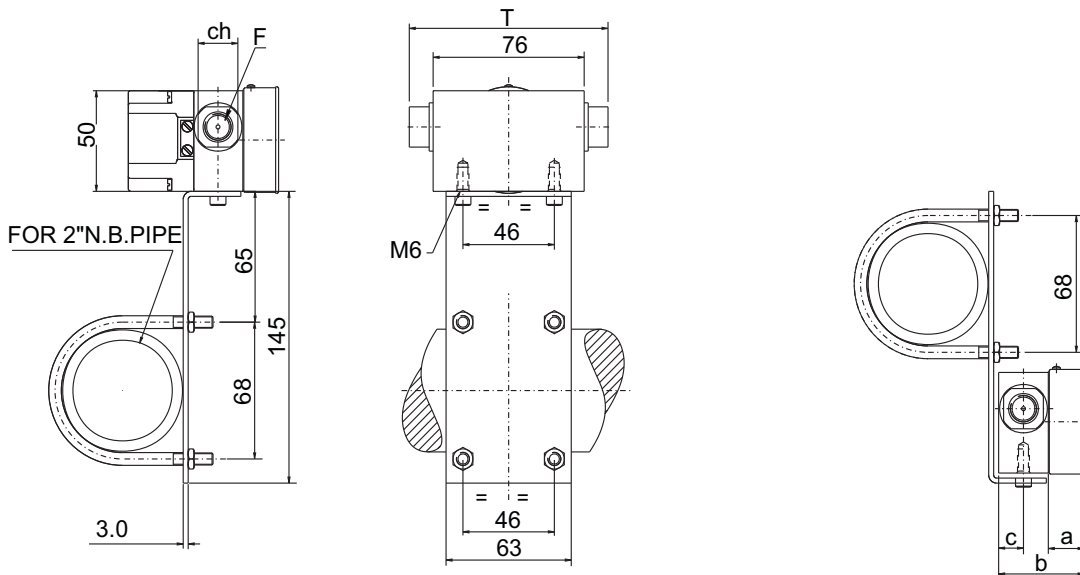

BRACKET MOUNTING FOR GAUGE+ SWITCH

BRACKET MOUNTING FOR GAUGE

DIAL Ø	F	a	b	c	T	ch
50 (2")	1/4"BSP - 1/4"NPT	18	43	12.5	100	20
63 (2.5")	1/4"BSP - 1/4"NPT	19	44	12.5	100	20
80 (3.5")	1/4"BSP - 1/4"NPT	19	44	12.5	100	20
100 (4")	1/4"BSP - 1/4"NPT	19	44	12.5	100	20
115 (4.5")	1/4"BSP - 1/4"NPT	19	44	12.5	100	20
150 (6")	1/4"BSP - 1/4"NPT	19	44	12.5	100	20

# 200 DPG (Piston Gauge)

## Gauge+Switch with Reed Contacts with DIN Plug at Back

DIAL $\varnothing$	F	d	b1
50 (2")	1/4"BSP - 1/4"NPT	53	102.5
63 (2.5")	1/4"BSP - 1/4"NPT	66	103.5
80 (3.5")	1/4"BSP - 1/4"NPT	83	103.5
100 (4")	1/4"BSP - 1/4"NPT	104.3	103.5
115 (4.5")	1/4"BSP - 1/4"NPT	119.7	103.5
150 (6")	1/4"BSP - 1/4"NPT	154.3	103.5

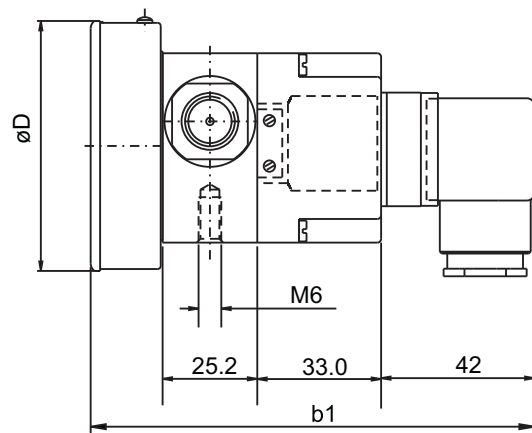
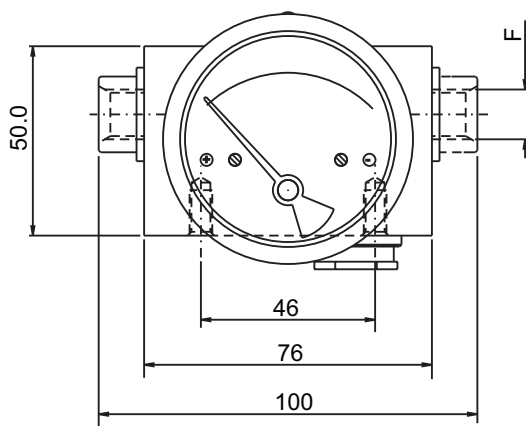
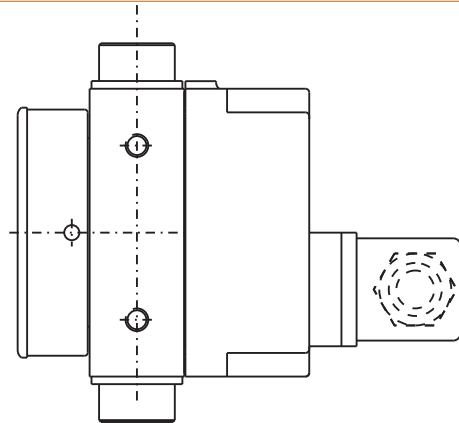

## Gauge+Switch with Reed Contacts with DIN Plug on Top

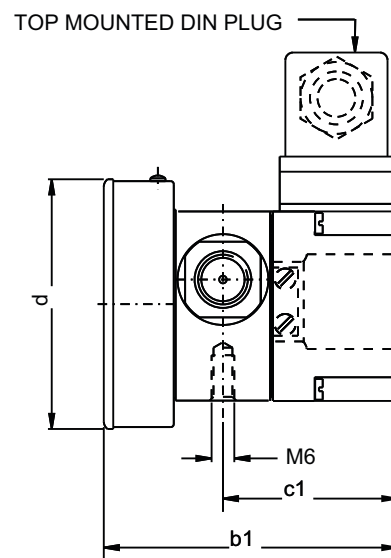
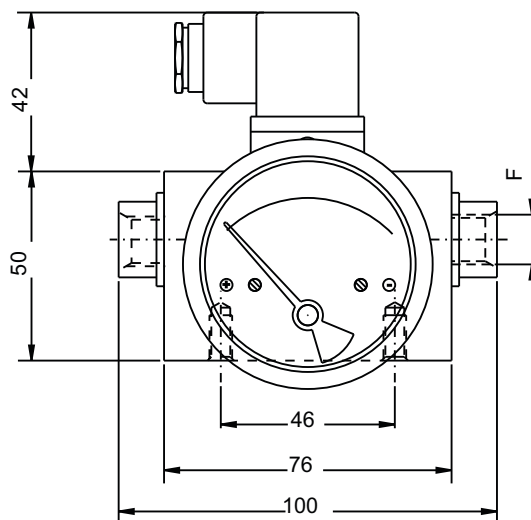

DIAL $\varnothing$	F	b1	c1	d
50 (2")	1/4"BSP - 1/4"NPT	78	47.5	53
63 (2.5")	1/4"BSP - 1/4"NPT	79	47.5	66
80 (3.5")	1/4"BSP - 1/4"NPT	79	47.5	83
100 (4")	1/4"BSP - 1/4"NPT	79	47.5	104.3
115 (4.5")	1/4"BSP - 1/4"NPT	79	47.5	119.7
150 (6")	1/4"BSP - 1/4"NPT	79	47.5	154.3

# 200 DPG (Piston Gauge)

Switch with DIN Plug at Back

F=1/4"NPT - 1/4"BSP

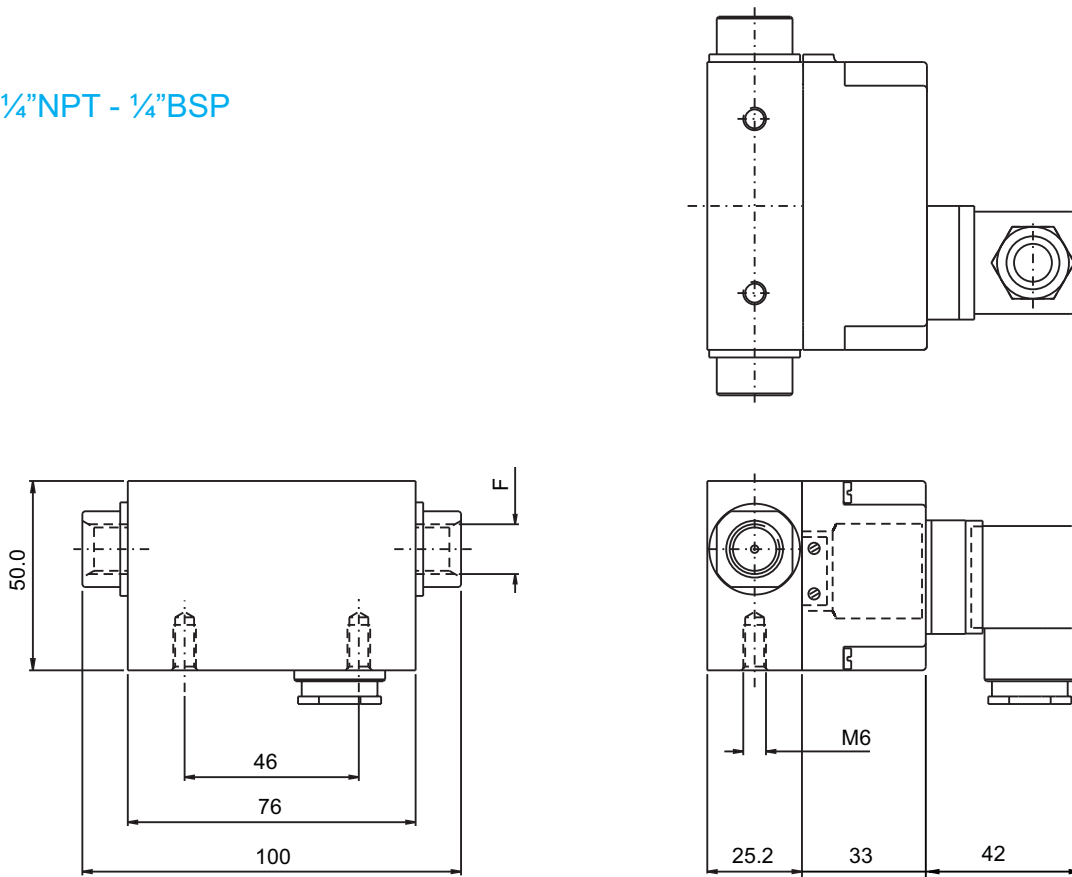

Switch with DIN Plug on Top

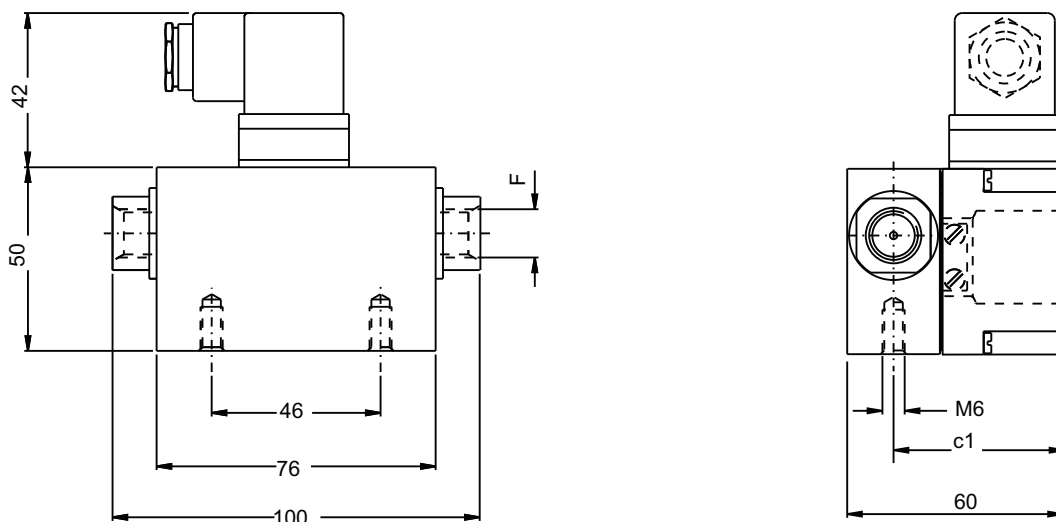

F=1/4"NPT - 1/4"BSP , C1=47.5

# 200 DPG

## (Piston Gauge)

Gauge+Switch with Reed Contacts with Terminal Strip & 1/2" NPT Conduit Connection

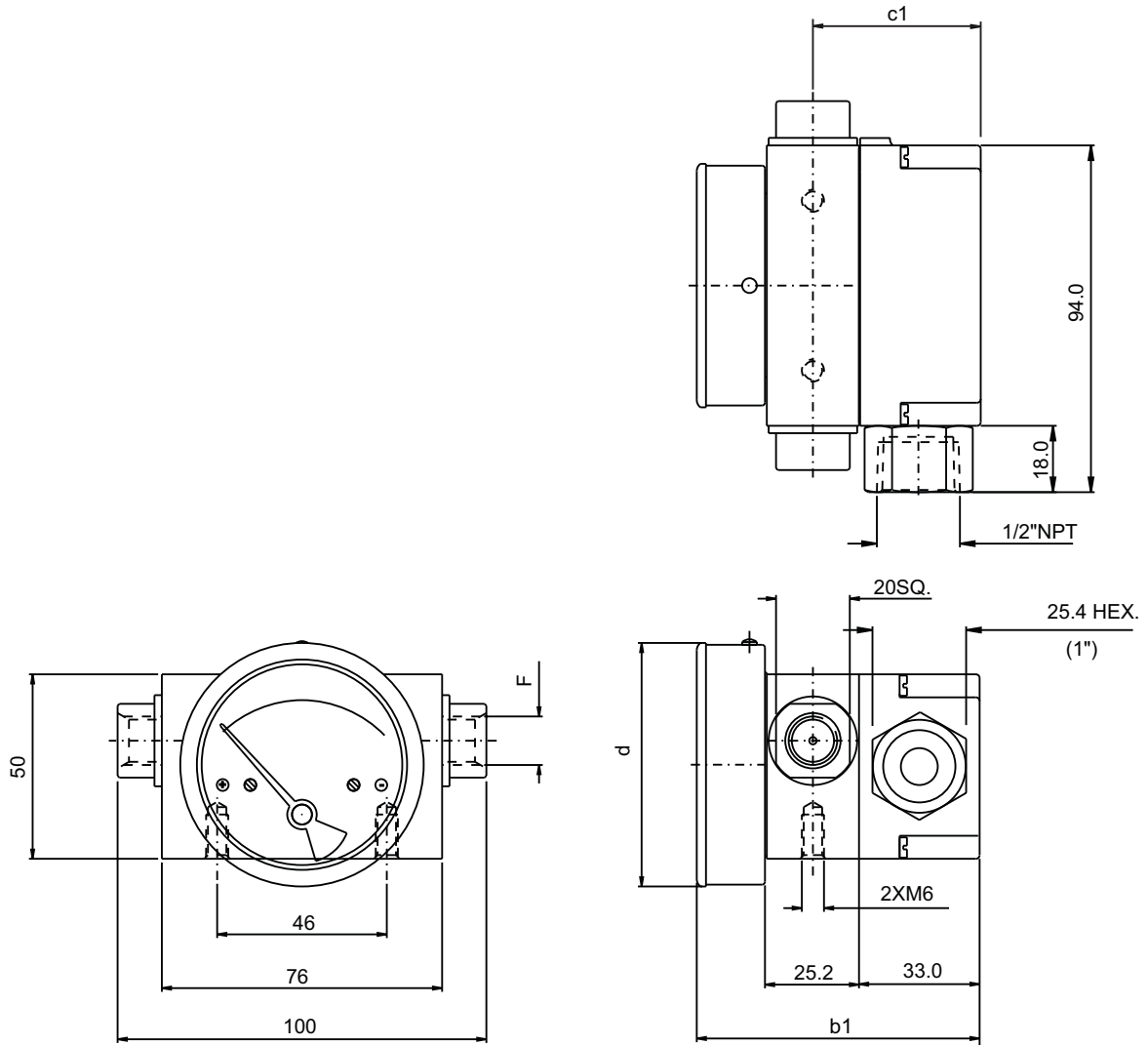

DIAL $\varnothing$	F	b1	c1	d
50 (2")	1/4"BSP - 1/4"NPT	78	47.5	53
63 (2.5")	1/4"BSP - 1/4"NPT	79	47.5	66
80 (3.5")	1/4"BSP - 1/4"NPT	79	47.5	83
100 (4")	1/4"BSP - 1/4"NPT	79	47.5	104.3
115 (4.5")	1/4"BSP - 1/4"NPT	79	47.5	119.7
150 (6")	1/4"BSP - 1/4"NPT	79	47.5	154.3